

Campagnolo[®]

CROCE D'AUNE[®]

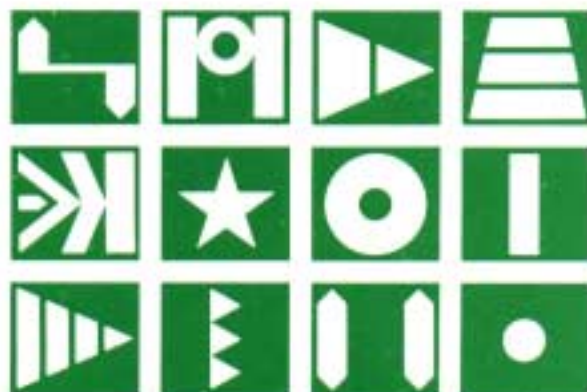

CROCE D'AUNE.







REAR DERAILLEUR AND FRONT DERAILLEUR

The basic problem a derailleur has to solve is that of moving its jockey wheel cage so that it follows the geometry of the freewheel. The traditional derailleur uses a vertically hung, jointed parallelogram to move the jockey wheel cage on an axis that is almost parallel to the axle of the wheel.

The new slant-parallelogram derailleurs have improved shifting by moving the jockey wheel cage on an axis that is parallel to the cone shape of freewheel. This allows the cage to be very close to each individual cog on the freewheel thus eliminating the over-shifting necessary with the traditional system.



The innovative design of the CROCE D'AUNE derailleur is an improvement on the above mentioned systems and achieves its efficiency through Campagnolo's patented "TWIN-AXLE System". The "TWIN-AXLE System" is an articulation of the geometry of the derailleur which combines two movements to move the jockey cage across the freewheel while keeping it equidistant from all the cogs regardless of how big or how small they are in diameter.

The "TWIN-AXLE System" of this new derailleur works in this way: when the gear cable is pulled the derailleur rotates on its pivot bolt (fig. A) causing the jockey cage to alter itself to suit the increasing diameters of the freewheel cogs. At the same time, a rigid, stainless steel arm on the diagonal of the parallelogram moves the cage plate along the freewheel

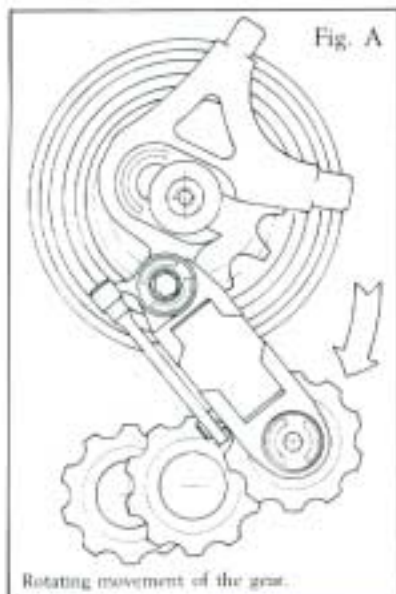

(fig. B) guiding the chain from one cog to another. The movement of the parallelogram is controlled by a return spring. This spring is not, however, preloaded like on other derailleurs which can cause needless friction. Thanks to the elimination of friction at this point the derailleur's shifting action is much lighter and smoother than other gear changers.

The "TWIN-AXLE System" of the CROCE D'AUNE derailleur is a new break-through in derailleur technology and is destined to set new standards for competition derailleurs. In races like the Giro d'Italia and Tour de France where steep mountain roads torture both

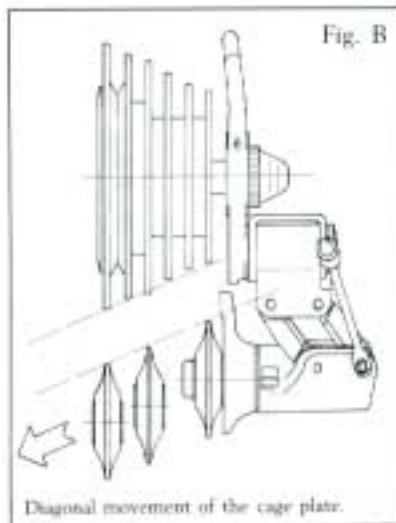

man and machine it is extremely important for the derailleur to perform flawlessly because one missed shift or slipped chain can be the difference between winning and losing.

The CROCE D'AUNE derailleur is adjusted in the normal way with limit stop screws. These screws have been located on the upper body instead of the parallelogram making them less susceptible to damage in a crash. The derailleur also has a set screw to fine tune its inclination and a built-in cable tensioner. The CROCE D'AUNE derailleur is available in two versions: the basic SM version and the LG

version for freewheels with sprockets up to 30 teeth.

The CROCE D'AUNE derailleur comes with Campagnolo's famous DOPPLER retrofriction shift levers as standard equipment. It is however compatible with Campagnolo shift levers SYNCRO 2 and FRICTION.

CROCE D'AUNE



	CROCE D'AUNE SM	CROCE D'AUNE LG
Gear change capacity = $(D + A) - (C + B) =$	30	33
Biggest sprocket utilizable = $A =$	28	30
Front changer capacity = $(D - C) =$	18	18



The front changer has been specifically designed for today's newest chains. It is extremely precise with a very low coefficient of friction. Built to withstand the rigors of professional racing it features an anodized aluminium body with Teflon treated, stainless steel, pivot pins. The cage is made of heat-treated, chromed, steel and is profiled to provide ultra fast shifts without having to trim it even when the chain is at extreme cross-over angles.

Besides the braze-on and clamp-on versions, there is also a front changer with an adjustable clamp for frames with tube diameters from 28 to 33 mm.



BRAKES

One of the many technically innovative components of the CROCE D'AUNE group are the brakes. They feature the "PENTA-DRIVE System", a new concept in braking developed by Campagnolo. With "PENTA-DRIVE System" the force applied to the brake levers is multiplied to provide greater stopping power at the rim's surface.

The "PENTA-DRIVE System" is made up of a double series of four stainless steel arms and a cable locking pivot. The arms are connected to five Teflon treated stainless steel pivots so that they form a pentagonal shape. When the brake cable is pulled, the cable locking pivot slides inside a guide built into the caliper body causing the interconnected arms to pivot at their joints and force the caliper arms, attached at two of these pivot points to move toward the rim.

The force being transferred to the two caliper arms is equally and automatically divided by the cable pivot guide. This insures that the brake will remain centered and that the same amount of force is applied by both brake pads, to the rim. The result is a smooth, powerful

braking action, progressively applied to the rim which eliminates slipping and lack of precision in stopping. Unequal application of force to both sides of the rim surface often occurs with traditional caliper brakes and no matter how slight or brief in duration can cause dangerous skidding at high downhill speeds. Campagnolo's "PENTA-DRIVE System" effectively eliminates this phenomena giving the rider complete confidence at any speed. Tremendous research and constant testing have gone into developing the compound for the CROCE D'AUNE brake pad. This compound has been developed to provide controlled deceleration





under any condition whether it be the cold, wet racing environment of Northern Europe or the dry sizzling heat of the California desert. The brake pad holders are uniquely designed so that they can be adjusted for correct toe-in and to compensate for any rim shape in order to provide 100% surface contact. The brake shoes themselves can be raised or lowered on the caliper arms as usual.

CROCE D'AUNE brake sets are equipped with our new exclusive brake levers featuring the patented "POWER GRADE System", complete with a push button type quick release mechanism for the fast and efficient opening of the brake caliper. The "POWER GRADE System" offers the possibility of micrometric adjustment between the force applied to the brake levers and the brake force response.

In addition, as optional, Record Compact brake levers are also available. The geometry of these levers has been designed for riders who want to reach the brake levers more easily. The Record Compact brake levers will mount 12 mm. closer to the handlebar than traditional levers.



CHAINWHEEL AND BOTTOM BRACKET

The CROCE D'AUNE crankset is the result of a design that combines the most sophisticated hot-forging techniques in the industry with computer designed pedal/chainwheel/bottom bracket coupling planes to produce one of the stiffest, most durable cranksets available.

The stem of the CROCE D'AUNE crank is connected to the center of the chainwheel and to two of the five arms that support the chainring. In line with the style launched by the Record crank, the CROCE D'AUNE design results in a single body with a curved surface.

The rigidity of this provides a steady working surface for the chainring so that it cannot be flexed, giving optimum transmission of energy to the chain. The bolt circle of the CROCE D'AUNE chainwheel is 135 mm. A complete series of chainrings are available in sizes of 39-47 teeth for the inner ring and 48-54 teeth for the outer ring. Crank lengths are supplied in 170, 172.5 and 175 mm sizes.

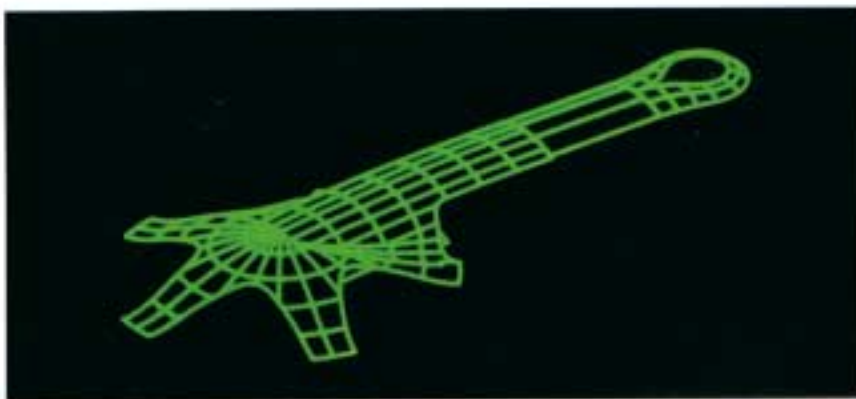



The bottom bracket is the same race-proven design that has won more races in professional competition than all others combined. It uses an axle and cups made of case-hardened steel. The rolling mechanisms are composed of hardened chromium steel balls with diameter 1/4" and held together in resin retainers.



The bottom bracket is available with the following threads: Italian mm 36x24f, BSC 1,370x24tpi, French M 35x1.



PEDALS

The pedals fitted to the CROCE D'AUNE group use Campagnolo's new "TRIPLE BEARING System", a patented system that allows an anatomical foot support with the ability to corner the bike at an angle 6° greater than is possible with normal pedals.

The "TRIPLE BEARING System" uses an axle made of only 60 mm long, on which rotates a body made of aluminium alloy. The rolling mechanism is made up of a roller bearing incorporated into the body on which is fitted the axle and a double series of 1/8" balls running in two races in opposite

positions machined into the axle. One of the bearing cups is incorporated into the pedal body while the other is adjustable with a 17 mm wrench.

The new "TRIPLE BEARING System" eliminated the need for bulky ball bearings in the other part of the pedal, giving the pedal body a tapered, streamlined shape that allows the bicycle to be cornered at an angle of as much as 34° (fig. A). This can allow the rider to corner at higher speeds especially in criteriums and mountain descents where precious seconds gained can make a big difference.

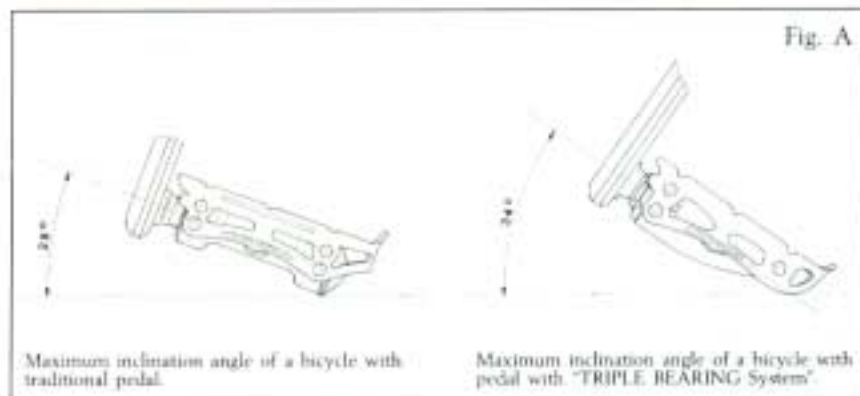



The pedals are available with the following threads: Italian/BSC 9/16"x20f, French 14x1,25.

The toe-clips for the CROCE D'AUNE pedals are available in small, medium and large; and with the new "MULTI-SIZE System". This new feature allows for the complete and total anatomic adjustment of the toe-clip in conjunction with the rider's foot. This is accomplished by one adjustment located where the toe strap passes through the toe clip. This is especially important for the cyclist that rides for a prolonged period of time.



HUBS

CROCE D'AUNE hubs are made of Silicon Aluminium alloy and have a special hole drilled in the center, protected with a clip, for lubrication. This lubrication point allows Campagnolo 02-ZPT grease to be injected into the hub. This method of lubrication, used by professional racing teams, has two effects:

- 1) The lubrication covers the axle, protecting it against damage

that might be caused by infiltration or damp condensation.

- 2) Both during application and due to rotation of the hub itself, the grease is pushed toward the bearing races supplying them with fresh lubrication.

The rolling mechanisms of the CROCE D'AUNE hubs are composed of case-hardened steel bearing races pressed into the body and chromium steel cones screwed onto the axle. In the ground and polished races run specially select-





ed. chromium steel ball bearings, 3/16" in front and 1/4" in the rear. They are protected by two dust covers which also have a hole for direct lubrication.

The hubs are available with the following drillings: 28, 32, 36. The threads are: Italian mm 35x24f, BSC 1,370"x24tpi, French M 34,7x1, ISO 1,375"x24f.

As it is well known, the quick release hub was originally designed by Campagnolo and became its first patent product. The quick re-



lease mechanism of this hub uses a hardened, tempered steel skewer and locknut and employs the classic eccentric closure design which remains the standard of the industry.



HEADSET-SEAT PIN

The CROCE D'AUNE head set is made of Avional aluminium alloy with precision ground steel bearing races and 1/4" diameter ball bearings held in place with resin retainers.

The CROCE D'AUNE headset also uses the new SELFORM system which protects the bearing races against pitting and irregular wear thanks to a dampening element placed between the cup and the race itself.

To protect the headset from the damaging effects of dirt and water thrown up by the front wheel a resin seal has been added to the lower bearing race.

The head set is available with the following threads: Italian 25,4x24f, BSC 1"x24tpi, French M 25x1.

The CROCE D'AUNE seat pin is made of die-cast silicon aluminium, drilled and shaped on State-of-the-Art automated machines which guarantee precision to one hundredth of a millimeter.

Thanks to this technological procedure, a delicate component such as the seat pin which is subject to sudden violent stress, is brought to a level of reliability beyond compare.

The available diameters are: 26.2, 26.4, 26.6, 26.8, 27, 27.2, 27.4 mm.

B000	"CROCE D'AUNE" Campagnolo group Basic composition:
Cat. No.	Description
B500	Subgroup brakes "PENTA-DRIVE System" (front and rear brake, double lever "POWER- GRADE System", cables and casings)
B100	Subgroup SM gear and braze-on front chan- ger
0271	"DOPPLER" braze-on levers (r.h. and l.h. levers, steel cables and casings)
B300	Subgroup small flange hubs (front and rear hub complete with quick release)
B040	Chainwheel set with incorporated extractor (r.h. crank width 135 with two chainrings, l.h. crank)
B0H0	Bottom bracket
B620-L	Subgroup pedals "TRIPLE-BEARING Sys- tem" (r.h. and l.h. pedal complete with alu- minium toe-clip and single layer leather strap)
C0D0	Aluminium head set
C0R2	Seat pin 180 mm. complete with locking screw and nut Ø 8

Subgroups and alternatives components:

Cat. No.	Description
B010-LG	LG gear
A055	Complete Record Compact brake lever, "PO- WER-GRADE System", cables fitted exter- nally
C022	Fixed clip-on front changer (pipes Ø 28,5 mm.)
C023	Adjustable clip-on front changer (pipes Ø from 28 to 33 mm.)
	"DOPPLER" levers complete with steel ca- bles and casings, versions:
0272	clip-on
0273	braze-on, on top-of-tube
	"FRICTION" levers complete with steel ca- bles and casings, versions:
0281	braze-on
0282	clip-on
0283	braze-on, on top-of-tube
	"SYNCRO 2" levers complete with steel ca- bles and casings, versions:
0221	braze-on, 6 speed
0222	clip-on, 6 speed
0223	braze-on, on-top-of-tube, 6 speed
0221-7	braze-on, 7 speed
0222-7	clip-on, 7 speed
0223-7	braze-on, on-top-of-tube, 7 speed
B620-A	Subgroup pedals "TRIPLE-BEARING Sys- tem" (r.h. and l.h. pedal complete with steel toe-clips and single layer leather strap)
B620-R	Subgroup pedals "TRIPLE-BEARING Sys- tem" (r.h. and l.h. pedal complete with "MULTI-SIZE System" toe-clips and single layer leather strap)
C0R2-S	Seat pin 130 mm. complete with fixing screw and nut Ø 8

- CAMPAGNOLD S.P.A. - VIA DELLA CHIESA, 4 - 36100 VICENZA - ITALY - Phone 0444/564993 - Telex 480074 CAMPA I - Telex 0444/565062
- CAMPAGNOLD S.A.R.L. - RUE DU CHATEAU D'EAU - 40020ERS DE TOURAINE - 37160 NEUILLE EN ST PIERRE - FRANCE - Phone 47-566549 - Telex 750373 WEIPRA - Telex 47-566779
- CAMPAGNOLD CORPORATION - 41 FARMFIELD PLACE - WEST CALDWELL, N.J. 07086 - U.S.A. - Phone 201-8528733 - Telex 705298 CAMPA CORP - Telex 201-852880

○ SERVICE AND TECHNICAL INFORMATION - CENTRAL (ITALY) - Phone 0444/571871
- U.S.A. - Phone 1090/USCAMP